

Basic Optics

© 2003 The Imaging Source Europe GmbH

All rights reserved

<http://www.1394imaging.com/>

Version: December 2003

Be honest: do you really know how to calculate the focal length of a lens? If so, you are an exception to the rule and can stop reading here !! For the rest of you, here is a second chance.

Back to square one

"*Piece of broken glass starts forest fire*"- a common headline during the summer. But how could this have happened? Due to the enormous distance between the Earth and the Sun, the Sun only appears as a tiny point emitting parallel rays of light (figure 1a) Should these parallel rays pass through a lens (or a piece of glass, which has similar characteristics) the rays would meet behind the lens at what is called the focal point.

But what happens if our point of light is so near to the lens that we can not assume to have parallel rays of light? They cross each other behind the focal point (figure 1b). If we take a look at the image of our point of light at the focal points position we will see a unclear blurred spot.

And so the question arises- "what is focusing?". Focusing is to increase the distance between the focal plane and the lens until the focal plane and the junction of the rays overlap each other (figure 1c).

Thus, for single points of light the situation is quite simple. But what happens to the image of screws, PCBs or plates of steel?

From points of light to images

A point of light does not necessarily originate directly from the sun, candles or lamps, it can also result from a reflection. Consider the surface of a reflective object as an ensemble of an infinite number of points of light. Now look at the arrow shown in Fig. 1d. The arrow head and it's tail form two points. If we trace the rays reflected from these two points to the lens, the image of the arrow appears inverted. All of the remaining (infinite) points of light are treated in the same way.

From single to compound lenses

Surely, playing with fire is one of the less desirable applications of lenses. In the context of optical measurement we use lenses to represent an object on an image sensor (for instance a CCD chip). The image created in this way (Fig. 1d) is the basis for various measurements, for example: size, position and surface quality.

However, this image is no longer produced by using a single lens but by a group of lenses termed "a compound lens". The quality of such compound lenses is much higher than that of single lens. For everyday use we can just consider the compound lens to be the "Ideal" single lens.

So, how do we choose the right lens? The most basic feature is the relationship between the size of the image and that of the object:

$$\text{Magnification} = \frac{\text{Size of image}}{\text{Size of object}}$$

For example; the length of a screw is 5cm and the resulting image should be 5 mm, the magnification is therefore 0.1. If, however, the screw size is only 0.5 mm and is to be represented by an image of 5 mm, the magnification is 10.

As Fig. 1d shows that magnification also depends on the working distance. The more distant the object the smaller the image. Thus, the use of the parameter magnification only makes sense if we know the working distance at the same time. You say this is too impractical? Okay - then we need a parameter which describes a lens more clearly. The solution is evident from our everyday life. It is the

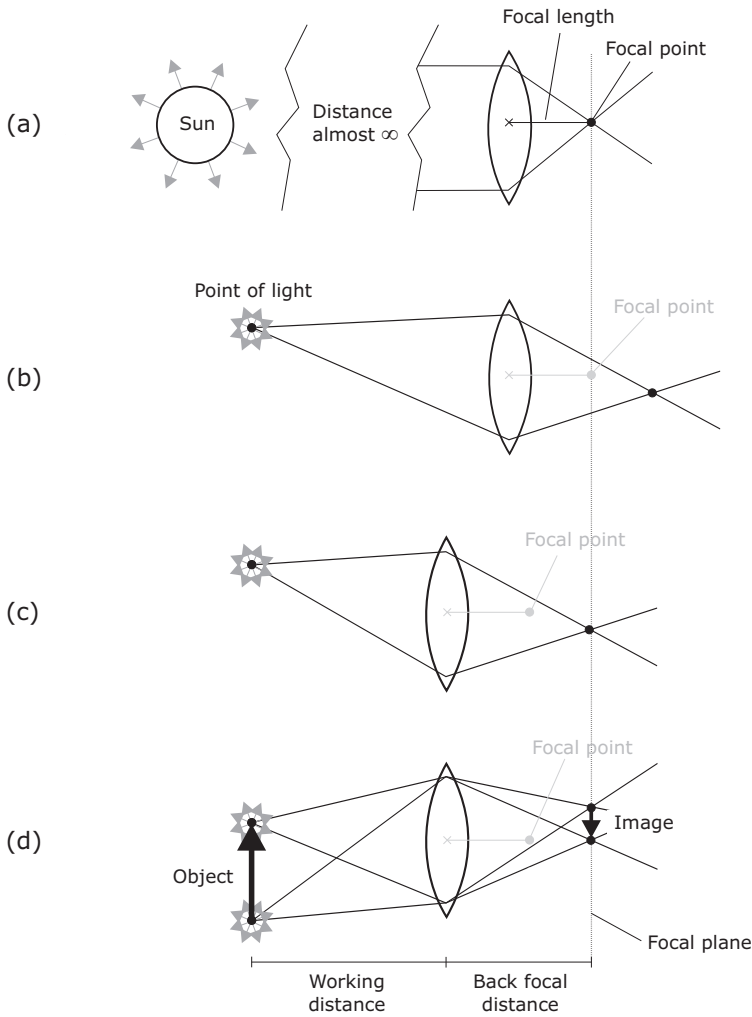

Fig. 1: From points of light to images

$$Focal\ length = \frac{Working\ distance * Size\ of\ image}{Size\ of\ object + Size\ of\ image}$$

Do vacation shots and optical measurement have something in common?

To be honest, very little. But the shooting of vacation snaps and optically measuring a plate of steel are both based on the same optical laws. Let us assume an image sensor with the same dimensions of a 35 mm film that has a height of 24 mm and a width of 36 mm. Our aim is to capture a 1000 m width of a beach at a distance of 500 m, for this we need the following focal length:

$$Focal\ length = \frac{500\ 000mm * 36mm}{1\ 000\ 000mm + 36mm} = 18mm$$

We exchange the 35 mm film for a typical CCD chip measuring 4.8 * 6.4 mm, the focal length is now considerably lower:

$$Focal\ length = \frac{500\ 000mm * 6.4mm}{1\ 000\ 000mm + 6.4mm} = 3.2mm$$

There is no beach without a Bay Watch kid !! Should we want to capture him completely on a 35 mm film at a distance of 500 m and a height of 2 m, we would require a

$$Focal\ length = \frac{500\ 000mm * 24mm}{2\ 000mm + 24mm} = 5\ 929mm$$

Such focal lengths are not usually found in basic camera equipment. Whether we like it or not we would have to move closer to the person. At a distance of 10 m we can fill the image on a 35 mm film with a more or less "normal" focal length of 120 mm.

Nature-lovers often struggle when taking photographs of their subjects which are usually very close rather than at a distance. If for instance, we approach an insect which has a height of 10 mm from a 30 cm distance, we can capture it on a 35 mm film with a focal length of

$$Focal\ length = \frac{300mm * 24mm}{10mm + 24mm} = 212mm$$

But have you ever tried to focus the same object using a „normal“ 200 lens at a distance of 30 cm ? Forget it !

The myth of extension rings and tubes

Some technical things are considerably overrated. This is particularly true for extension rings and tubes which are simply inserted between the lens and the camera to increase the back focal length (Fig. 1d). But what advantage does this have? The closer a point of light is to the lens the more distant behind the lens the rays cross each other. Thus, the back focal length has to become longer and longer to yield a sharp image (Fig. 1b and 1d). Common lenses modify the back focal length by the use of a helical mount which moves the single lens in the lens housing. This movement of the lens obviously has mechanical limits. One of these limits determines the maximum back focal length and therefore the least possible object distance (also called MOD = minimum object distance). Should we need to get closer to the desired object we simply have to increase the MOD by adding extension rings or tubes.

This is actually quite a simple effect although it is amazingly surrounded by bizarre myths, such as an alledged increase - or according to another belief a decrease in field-depth. All of this is nonsense! Let us concentrate on some practical details which are important to everyday usage as, for example, the question

Why C-mount lenses?

In olden times films were taken by pick-up tube cameras. The external diameter of such a tube was 1/2", 2/3" or 1" while the light sensitive area at the front side of the tube was accordingly smaller. Fig. 2 shows their dimensions. These remain the basis for todays dominating CCD chips.

The mounting lens of the pick-up tube camera is called C-mount (C as in Cinema). Here, we are talking about a 1" thread which offers a simple, compact and robust basis for interchangeable lenses. The CS-mount version only differs from this in the so-called flange focal distance (Fig. 3).

The different dimensions of pick-up tubes and CCDs are reflected in the various formats of the lenses. This is unfortunate – as it falsely leads to the belief that for example: a 1/3" CCD would require a 1/3" lens.

Everything revolves around the image circle

White walls may be a little boring, but are suitable now and again for some thought-provoking experiments. Imagine pointing a lens at such a wall. What would the image be? A bright round spot which is just as boring as the wall (experts call this an "image circle"). In the case of a 1/3" lens it's image circle is slightly larger than the diagonal of a 1/3" CCD. Thus, our bright spot covers our 1/3" CCD completely. Had we used a 1/2" CCD instead of the 1/3" CCD the bright spot would not have covered the CCD and it's corners would remain dark. To sum up: The format of the lens has to be **larger than or equal to** the format of the CCD.

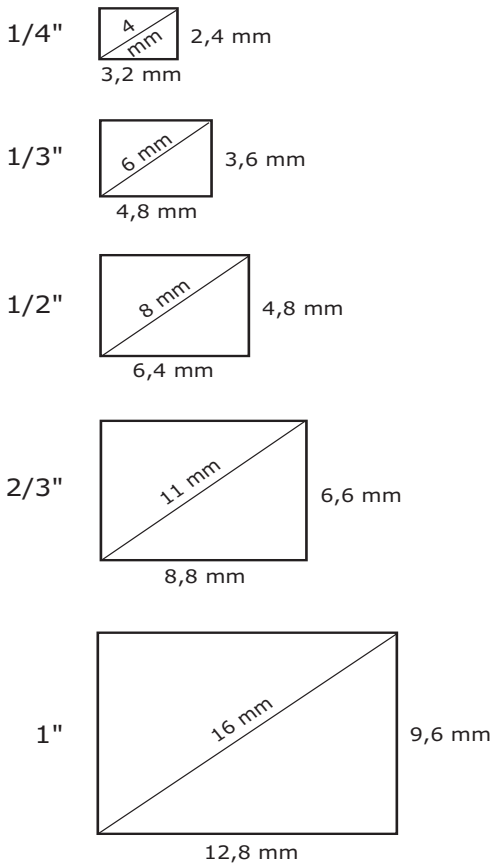

Fig. 2: CCD formats

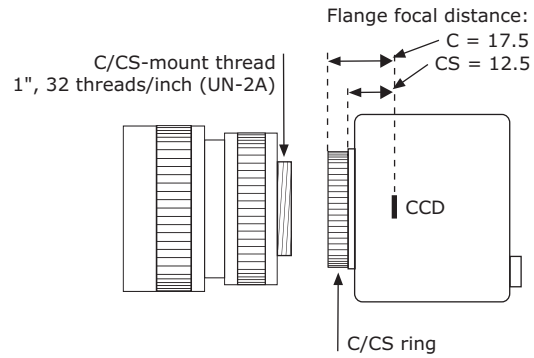

Fig. 3: The C-mount thread.

Unfortunately, lenses are not perfect and are prone to flaws which mainly occur around the rims. Thus, it is advisable to choose a lens format which is as large as possible. The second possible measure is just as simple. We prevent the rays of light going through the outer parts of the lens and therefore no defects can arise. Our tool for this is the iris.

An "indepth view"

An iris does not only decrease lens flaws, it also affects the sharpness. But what actually is "sharp"? In Fig. 4a two points of light A and B create two images A' and B'. The back focal length (as previously shown in Fig. 1d) is set so that the image A' is exactly at the CCD. Now that is sharp!!



Abb. 4: What is sharp?

Point B is closer to the lens and therefore image B' lies behind A'. Due to this, the image of B is an unclear spot on the CCD. The experts term this as a "blurred spot".

The above conclusion about what is "sharp" would mean it is impossible to focus a three-dimensional object. Only one sectional view of the object would actually be in focus whilst the rest of the object remained blurred. But why doesn't this happen in practice? In reality, our eyes do not register a small blurred spot as being blurred. This tolerance of our eyes is the basis for the effect called "depth of field". In the case of a 35 mm film a blurred spot smaller than 1/30 mm is registered as "sharp". In the case of a CCD, the size of the pixel can be defined as a

blurred spot. As a rule of thumb, the pixel size of a modern CCD is about $5 * 5 \mu\text{m}$.

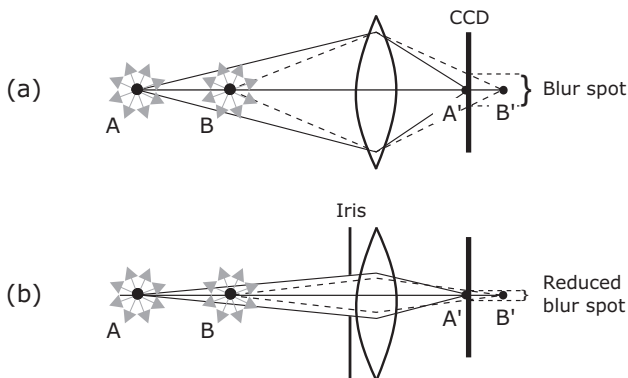
In practice, it is rarely necessary to calculate depth of field exactly. Alas, just like the subject "extension tube or ring" - depth of field is often a matter of belief rather than a matter of fact. Therefore, it is worth having a closer look at depth of field formula in order to find the correlation:

$$\text{Limits of depth of field} = \frac{\text{Working distance}}{1 \pm \text{Blur spot} * \text{Iris} * \frac{\text{Working distance} - \text{Focal length}}{\text{Focal length}^2}}$$

Let us assume we would like to inspect the quality of bolts during the production process using a megapixel camera DFK 31F03. The diameter of each bolt is 10 mm and the working distance from the camera is 100 mm. As the DFK 31F03 is equipped with a 1/3" CCD (see Fig. 3) we require a focal length of

$$\text{Focal length} = \frac{100\text{mm} * 3.6\text{mm}}{10\text{mm} + 3.6\text{mm}} = 26.5\text{mm}$$

to portray the bolt completely. We could of course use a 25mm off-the-shelf C-mount lens. Assuming a blurred spot of $5 \mu\text{m}$ we would then have a sharp image in the following area:

$$\text{Near limit of the depth of field} = \frac{100\text{mm}}{1 + 0.005\text{mm} * 1.4 * \frac{100\text{mm} - 25\text{mm}}{25\text{mm}^2}} = 99.92\text{mm}$$

$$\text{Far limit of the depth of field} = \frac{100\text{mm}}{1 - 0.005\text{mm} * 1.4 * \frac{100\text{mm} - 25\text{mm}}{25\text{mm}^2}} = 100.08\text{mm}$$

Should we require the image to be sharper there is only one thing for it - close the iris.

Let us try an iris of 4

$$\text{Near limit of the depth of field} = \frac{100\text{mm}}{1 + 0.005\text{mm} * 4 * \frac{100\text{mm} - 25\text{mm}}{25\text{mm}^2}} = 99.76\text{mm}$$

$$\text{Far limit of the depth of field} = \frac{100\text{mm}}{1 - 0.005\text{mm} * 4 * \frac{100\text{mm} - 25\text{mm}}{25\text{mm}^2}} = 100.24\text{mm}$$

Although the F-stop has been increased by a factor of 3 the improvement is nothing significant. This is caused by the strong influence of the focal length. Should we use a 12 mm lens (and thus halve the focal length) things would look better:

$$\text{Near limit of the depth of field} = \frac{100\text{mm}}{1 + 0.005\text{mm} * 4 * \frac{100\text{mm} - 12\text{mm}}{12\text{mm}^2}} = 98.79\text{mm}$$

$$\text{Far limit of the depth of field} = \frac{100\text{mm}}{1 - 0.005\text{mm} * 4 * \frac{100\text{mm} - 12\text{mm}}{12\text{mm}^2}} = 101.23\text{mm}$$

But unfortunately, the image of the bolts would only cover half of the CCD chip. Should the image still not be acceptable the only adjustment that can be made is to reduce the iris further. This would then need to be compensated with more light and/or by lengthening the exposure time of the camera.

In conclusion; depth of field is reliant upon 3 parameters:

Blur spot: The smaller the blur spot, the smaller the depth of field.

Iris: The smaller the F-stop (the more "open" the iris), the smaller the depth of field.

Focal length: The larger (!) the focal length, the smaller the depth of field. The relationship is quadratic. Thus, even a small increase of the focal length leads to a considerable decrease of the depth of field.

As previously mentioned - there are various beliefs regarding depth of field. An especially popular assumption, is that special forms of lenses (as for instance the so-called telecentric lenses) have a "better depth of field". But actually, depth of field is dependant upon the following three parameters; blur spot, iris and focal length.

There is still plenty more to come

For example, about the field of view, close-up lenses, macro lenses, telecentric lenses and above all, about the amazing fact that images which are slightly out of focus lead to more precise measuring results. We intend to elaborate on these topics from time to time and to inform you accordingly per email.....until then, have lots of fun and success.

By the way!! do not forget that we are available to answer any further queries you may have, feel free to contact us at any time.